

FULL TILT BOOGIE RACING CUSTOM FLOATING ROTOR ORDER FORM

Today's Date: _____

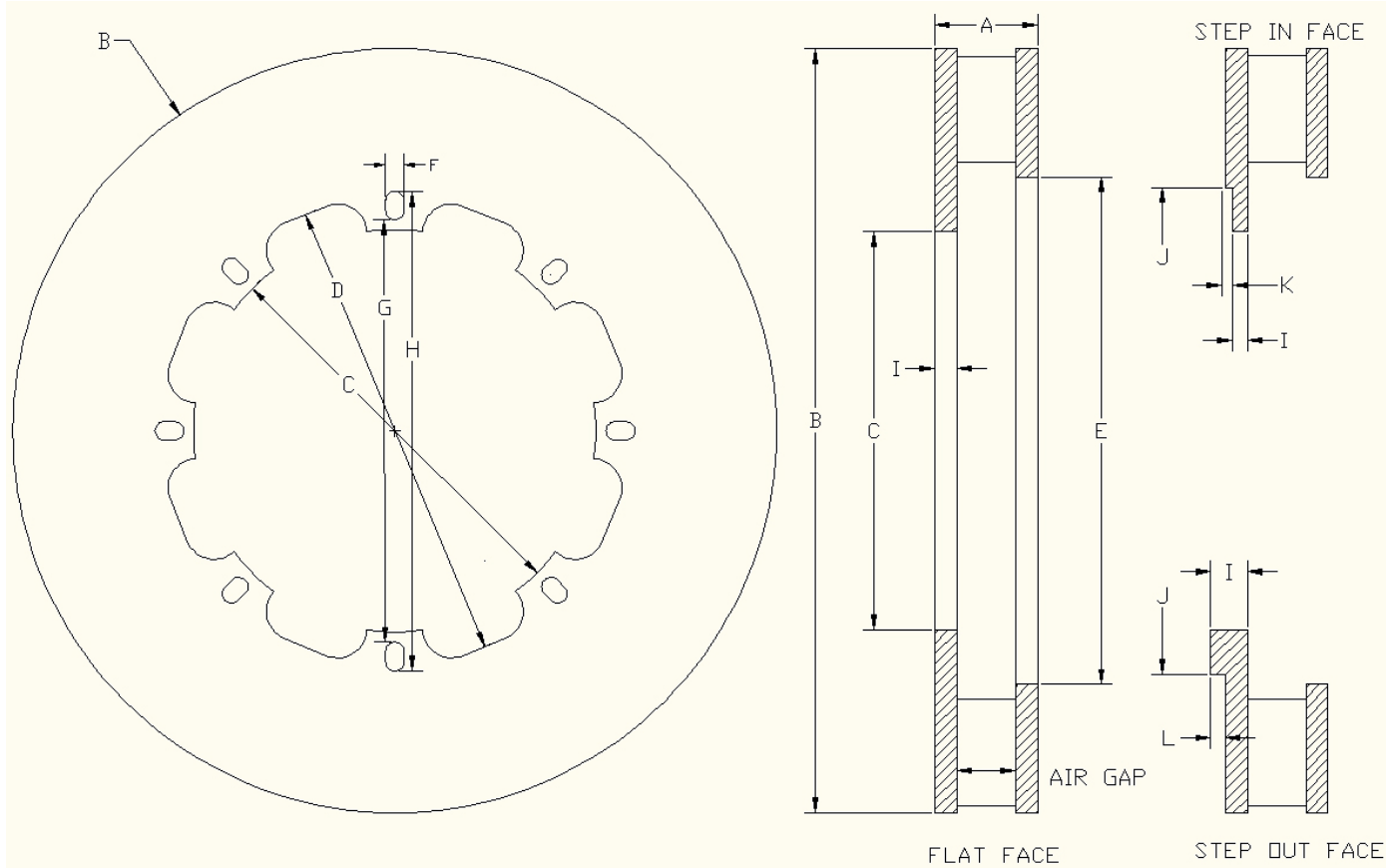

A = THICKNESS _____

B = DIAMETER _____

C = BORE OF FLANGE _____

D = SCALLOP TO SCALLOP _____

E = BORE OF EYE _____

F = SLOT WIDTH _____ # OF SLOTS _____

G = INSIDE SLOT DIM. _____

H = OUTSIDE SLOT DIM. _____

I = FLANGE THICKNESS _____

J = STEP DIAMETER _____

K = STEP DEPTH _____

L = STEP HEIGHT _____

AIR GAP _____

SLOTTING X 5 AGAINST VANING YES NO

STRESS RELIEVE YES NO

PLATING, CLEAR ZINC YES NO

BALANCE YES NO

MICRO FINISH YES NO

NOTE: DOUBLE CHECK ALL SIZES FOR CUSTOM ROTORS AND SIGN BELOW. NO ROTORS WILL BE MADE WITHOUT BEING SIGNED FOR APPROVAL. ABSOLUTELY NO RETURNS ON ANY CUSTOM ROTOR MADE TO CUSTOMER SPECIFICATIONS.

SIGNED: _____ DATE: _____